

KLINER

Hand Wash with knife Sterilizer



CLEAN HANDS AND CLEAN KNIVES

We have carefully studied the problems of maintaining hygiene standards in large kitchens and in particular the continuous use of when preparing food for cooking.

KLINER is the answer. We have designed a combined washer and knife sterilizer to solve the hygiene problem in a practical way.

KLINER - has a pedal to operate the water supply (instead of a tap) which prevents dirt etc. passing from hands to tap and then subsequently back to hands and also knives again.

Can be situated at the workplace, taking very little room and easily installed.

Sterilized knives are ready for use.

Provides a mixing tap with water at the desired temperature.

Water consumption is low due to the pedal operation which has an instant stop/start control.

With KLINER the very best working conditions are achieved and will conform to the highest standards of hygiene.

Wilma

LA SCIENZA DELLE GRANDI CUCINE

KLINER

Hand Wash with knife Sterilizer

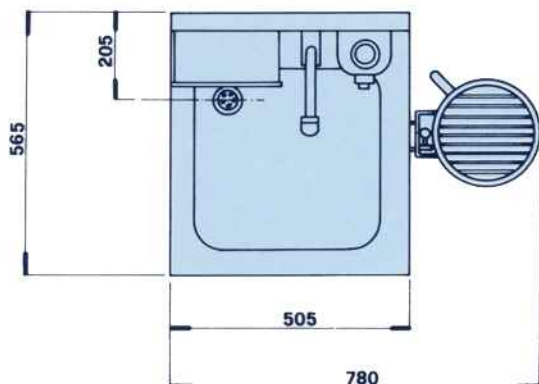
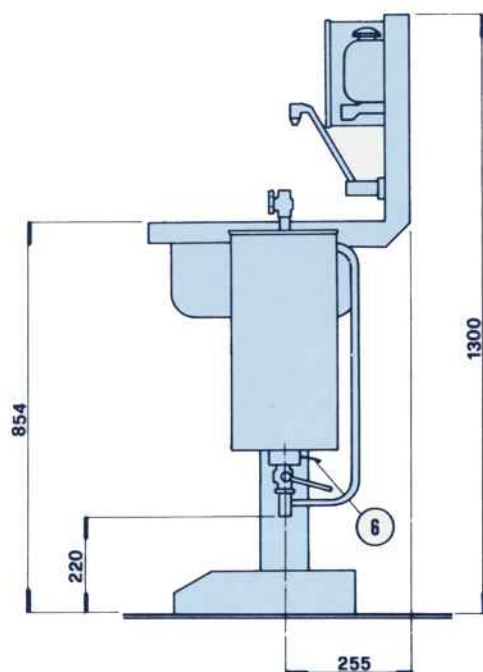
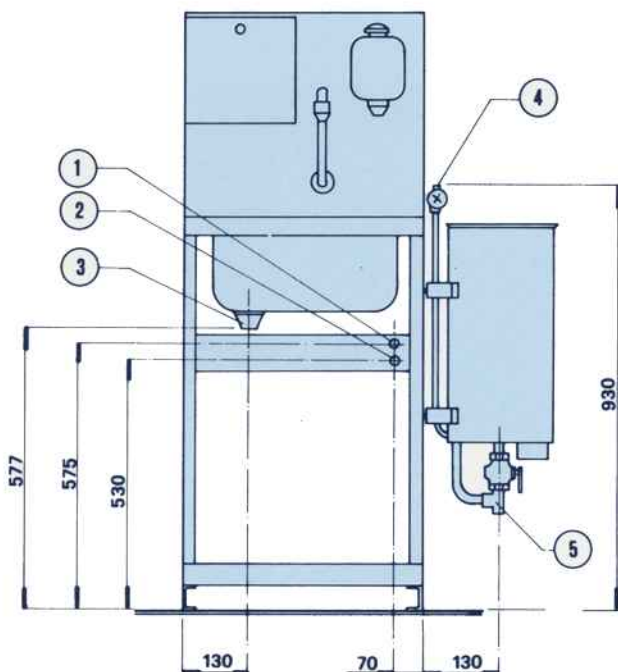

FEATURES

CONSTRUCTION

Handwash:

- Sink and general structure in stainless steel 18/10.
- Gooseneck water pipe.
- Mixer control.
- Pedal control.
- Sink equipped with overflow pipe and plug with chain.
- Liquid soap dispenser and paper towel dispenser

Sterilizer:

- Drum made of stainless steel 18/10 with overflow pipe.
- Can be mounted on left or right hand side of sink.
- Thermostat for water temperature regulation.
- Removable knife grid.
- Water cut-off cocks.

SPECIFICATIONS

- | | |
|-----------------------------|------------------|
| • Single phase power supply | 230 V |
| • Power absorption | 2 kW |
| • Sink dimensions | mm 400x400x190 h |
| • Total weight | 25 Kg |

DIMENSIONS

Installation drawing quoted

- | | |
|--------------------------|--------|
| 1 Hot water inlet | Ø 1/2" |
| 2 Cold water inlet | Ø 1/2" |
| 3 Wash-basin drain pipe | DN40 |
| 4 Sterilizer water inlet | Ø 3/8" |
| 5 Sterilizer drain pipe | Ø 3/4" |
| 6 Power connection | |



DESIGNED AND MANUFACTURED
TO CE STANDARDS

ISO 9001
registered by
GASTEC

Wilma

LA SCIENZA DELLE GRANDI CUCINE